

Ecophon Advantage™ A

Ecophon Advantage™ A has an exposed grid system with each tile individually demountable for easy access to soffit above. For applications requiring an easy-install suspended ceiling to meet the essential functional demands.

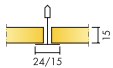

SYSTEM RANGE



Size, mm	600x600	1200x600
Connect T15	•	•
Connect T24	•	•
Thickness (THK)	15	15
Inst. Diagr.	M119, M271	M119



Advantage A tile

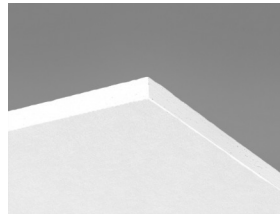

Advantage A tile

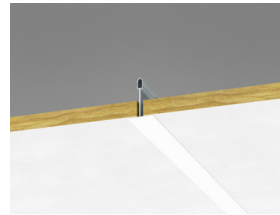

Section of Advantage A system with Connect T24



Advantage A system with Connect T24

Acoustic



Sound Absorption:

Test results according to EN ISO 354. Classification according to EN ISO 11654, and the single value ratings for Noise Reduction Coefficient, NRC and Sound Absorption Average, SAA according to ASTM C 423.

α_p , Practical sound absorption coefficient

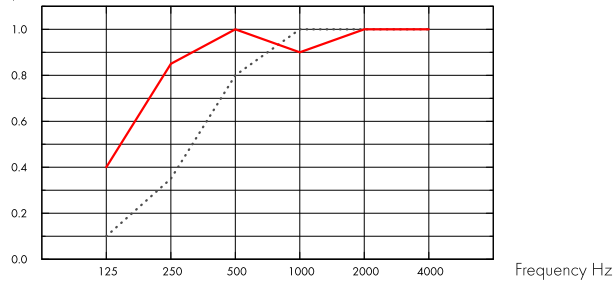

..... Advantage A 15 mm, 50 mm o.d.s.

— Advantage A 15 mm, 200 mm o.d.s.

o.d.s = overall depth of system

THK mm	o.d.s. mm	α_p , Practical sound absorption coefficient						α_w	Sound absorption class
		125 Hz	250 Hz	500 Hz	1000 Hz	2000 Hz	4000 Hz		
15	50	0.10	0.35	0.80	1.00	1.00	1.00	0.65	C
15	200	0.40	0.85	1.00	0.90	1.00	1.00	1.00	A

THK mm	o.d.s. mm	NRC	SAA
15	50	0.80	0.81
15	400	0.85	0.88

Indoor Air Quality



Certificate / Label	G35xxxxxx articles	37xxxxxx articles
Eurofins Indoor Air Comfort®	IAC Gold	IAC Gold
French VOC	A+	A+
Finnish M1	•	



Carbon footprint



	kg CO ₂ equiv/m ²
Advantage	1,98

Life-cycle stages A1 to C4 from EPD, in conformity with ISO 14025 / EN 15804



Circularity

Minimum post-consumer recycled content	48%
Recyclability	Fully recyclable



Fire safety

Country	Fire standard	Class
Europe	EN 13501-1	A2-s1,d0

The glass wool core of the tiles is tested and classified as non-combustible according to EN ISO 1182.



Humidity Resistance

Class C, relative humidity 95% and 30°C, according to EN 13964:2014



Visual appearance

White 500. Nearest NCS colour code; NCS S 0500-N. 83 % light reflectance. (The tiles need to be installed in accordance with the arrows on the back of the tile in order to get optimal visual appearance).



Cleanability

Weekly dusting and vacuum cleaning.



Accessibility

The tiles are easily demountable. Minimum demounting depth according to installation diagrams.



Installation

Installed according to installation diagrams, installation guides and drawing aid. (The tiles to be installed according to the arrows on the back of the tile.)



System weight

	kg/m ²
Advantage A	1,2
Advantage A + Connect grid system	2,2

Weight information is indicative and subject to variation.



Mechanical properties

See table about Max live load and Min load bearing capacity and Functional demands, Mechanical properties at www.ecophon.com.



CE

Ecophon ceiling systems are CE marked according to the European harmonized standard EN 13964:2014. CE marked construction products are covered by a Declaration of Performance (DOP) which enables customers and users to easily compare performance of products available on the European market.

INSTALLATION DIAGRAM (M119) FOR ECOPHON ADVANTAGE A

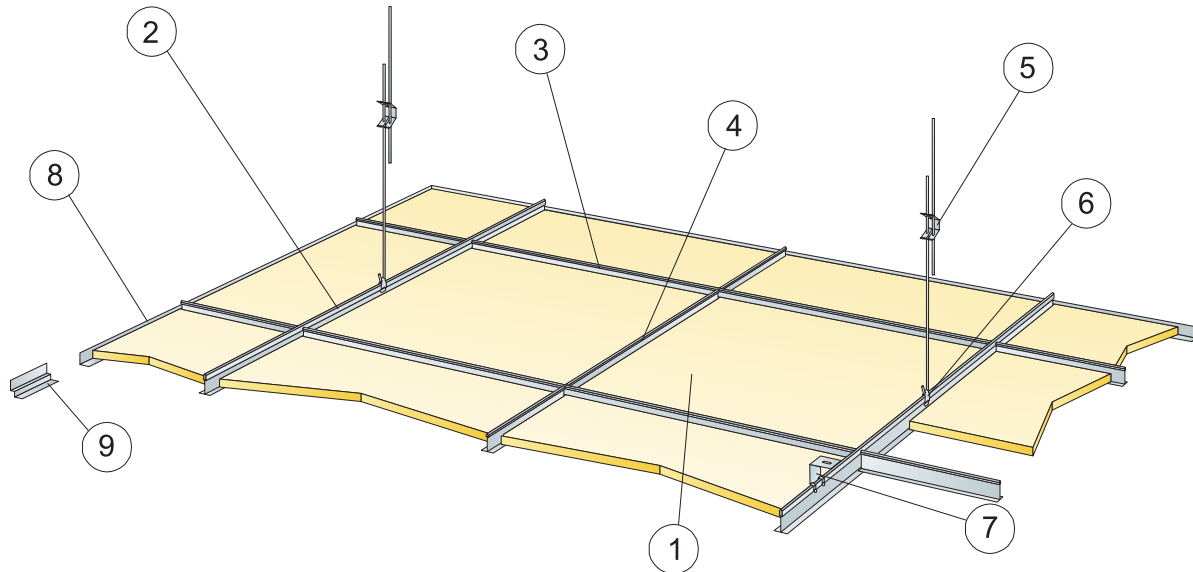

© Ecophon Group

QUANTITY SPECIFICATION (EXCL. WASTAGE)

	Size, mm	
	600x600	1200x600
1 Advantage A	2,8/m ²	1,4/m ²
2 Connect T24 or T15 Main runner, installed at 1200 mm centres (max. distance from wall 600 mm, can be extended up to 1200 mm if no live load between Main 0,9m/m ² runner and wall).	0,9m/m ²	0,9m/m ²
3 Connect T24 or T15 Cross tee, L=1200 mm, installed at 600 mm centres	1,7m/m ²	1,7m/m ²
4 Connect T24 or T15 Cross tee, L=600 mm	0,9m/m ²	-
5 Connect Adjustable Hanger, installed at 1200 mm centres (max. distance from wall 600 mm)	0,7/m ²	0,7/m ²
6 Connect Hanger Clip (not to be used in swimming hall environments)	0,7/m ²	0,7/m ²
7 For direct installation: Connect Direct Bracket, installed at 1200 mm centres	0,7/m ²	0,7/m ²
8 Connect Angle Trim, fixed at 300 mm centres	as required	as required
9 Connect Shadow-line Trim, fixed at 300 mm centres	as required	as required
Δ Min. overall depth of system, with adjustable hanger: 100 mm, with direct bracket: 50 mm	-	-
δ Min. demounting depth: 120 mm (130 mm with 1200x1200)	-	-
For luminaire integration in panels use Connect Bridging	-	-

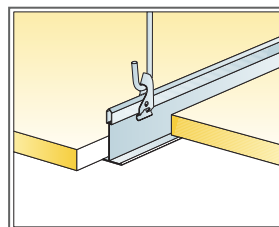
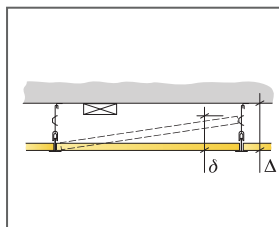

Suspension with adjustable hanger and clip

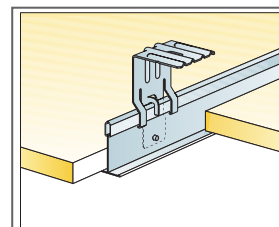

Suspension with direct bracket

Size, mm	Max live load [N]	Min load bearing capacity [N]
600x600x15	50	160
1200x600x15	50	160

Live load/load bearing capacity

INSTALLATION DIAGRAM (M271) FOR ECOPHON ADVANTAGE A, CONNECT T24 MAIN RUNNER INSTALLED AT 1800 MM CENTRES

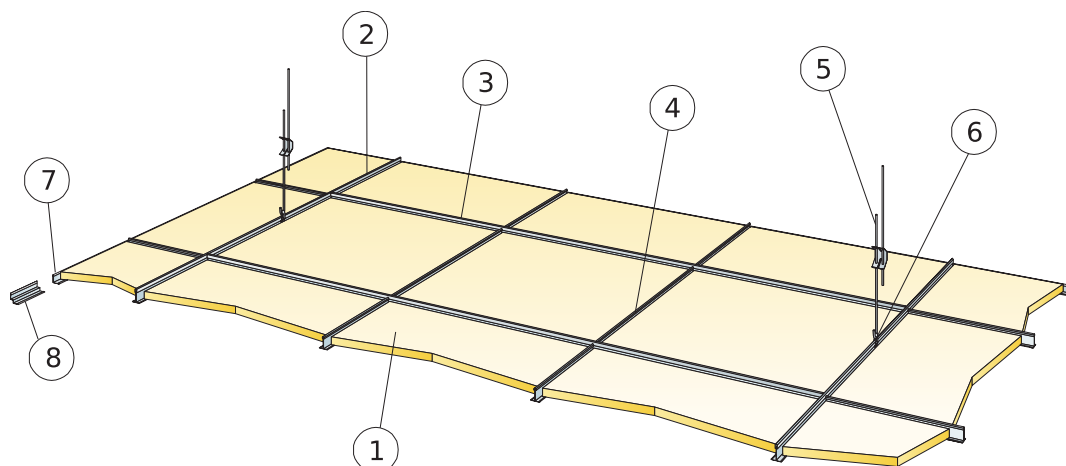

© Ecophon Group

QUANTITY SPECIFICATION (EXCL. WASTAGE)

	Size, mm
	600x600
1 Advantage A	2,8/m ²
2 Connect T24 Main runner, installed at 1800 mm centres (max. distance from wall 600 mm, can be extended up to 1200 mm if no live load between Main runner and wall).	0,56m/m ²
3 Connect T24 Cross tee, L=1800 mm	1,7m/m ²
4 Connect T24 Cross tee, L=600 mm	1,1m/m ²
5 Connect Adjustable hanger, installed at 1200 mm centres (max. distance from wall 600 mm)	0,46/m ²
6 Connect Hanger clip	0,46/m ²
7 Connect Angle trim, fixed at 300 mm centres	as required
8 Alt. Connect Shadow-line Trim, fixed c300	as required
Δ Min. overall depth of system, with adjustable hanger: 100 mm, with direct bracket: 50 mm	-
δ Min. demounting depth: 120 mm	-

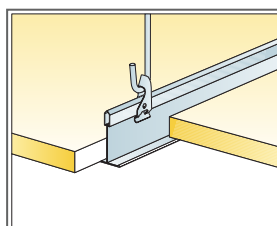
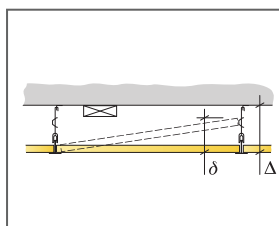

Suspension with adjustable hanger and clip

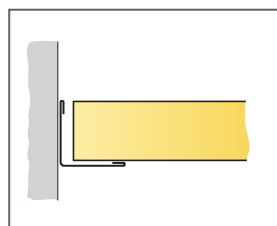

Straight cut, panel resting on wall trim

Size, mm	Max live load [N]	Min load bearing capacity [N]
600x600x15	20	160

Live load/load bearing capacity

Ecophon Advantage™ E

Ecophon Advantage™ E has a recessed visible grid and a tegular edge design, creating a ceiling with a shadow effect to accentuate each tile and partially conceal the grid system. For applications requiring an easy-install suspended ceiling and meets essential functional demands.



SYSTEM RANGE

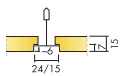

Size, mm	600x600	1200x600
Connect T15	•	•
Connect T24	•	•
Thickness (THK)	15	15
Inst. Diagr.	M122, M272	M122



Advantage E tile

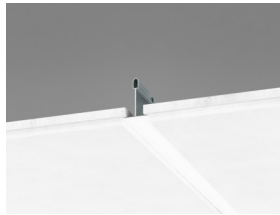

Section of Advantage E system with Connect T24



Advantage E system with Connect T24

Acoustic



Sound Absorption:

Test results according to EN ISO 354. Classification according to EN ISO 11654, and the single value ratings for Noise Reduction Coefficient, NRC and Sound Absorption Average, SAA according to ASTM C 423.

α_p , Practical sound absorption coefficient

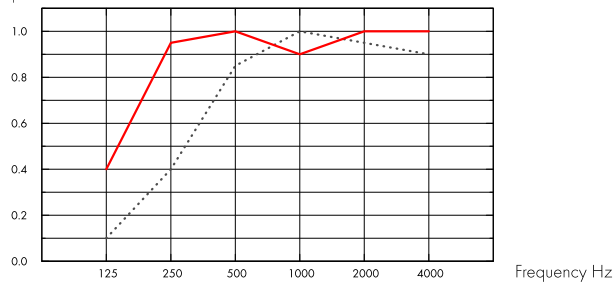

.... Advantage E 15 mm, 60 mm o.d.s.

— Advantage E 15 mm, 200 mm o.d.s.

o.d.s = overall depth of system

THK mm	o.d.s. mm	α_p , Practical sound absorption coefficient						α_w	Sound absorption class
		125 Hz	250 Hz	500 Hz	1000 Hz	2000 Hz	4000 Hz		
15	60	0.10	0.40	0.85	1.00	0.95	0.90	0.70	C
15	200	0.40	0.95	1.00	0.90	1.00	1.00	1.00	A

THK mm	o.d.s. mm	NRC	SAA
15	60	0.80	0.80
15	200	0.95	0.95
15	400	0.85	0.87

Indoor Air Quality



Certificate / Label	G35xxxxxx articles	37xxxxxx articles
Eurofins Indoor Air Comfort®	IAC Gold	IAC Gold
French VOC	A+	A+
Finnish M1	•	



Carbon footprint



	kg CO ₂ equiv/m ²	Life-cycle stages A1 to C4 from EPD, in conformity with ISO 14025 / EN 15804
Advantage E	1,98	



Circularity

Minimum post-consumer recycled content	47%
Recyclability	Fully recyclable



Fire safety

Country	Fire standard	Class
Europe	EN 13501-1	A2-s1,d0

The glass wool core of the tiles is tested and classified as non-combustible according to EN ISO 1182.



Humidity Resistance

Class C, relative humidity 95% and 30°C, according to EN 13964:2014



Visual appearance

White 500. Nearest NCS colour code; NCS S 0500-N. 83 % light reflectance. (The tiles need to be installed in accordance with the arrows on the back of the tile in order to get optimal visual appearance).



Cleanability

Weekly dusting and vacuum cleaning.



Accessibility

The tiles are easily demountable. Minimum demounting depth according to installation diagrams.



Installation

Installed according to installation diagrams, installation guides and drawing aid. (The tiles to be installed according to the arrows on the back of the tile.)



System weight

	kg/m ²
Advantage E	1,3
Advantage E + Connect grid system	2,3

Weight information is indicative and subject to variation.



Mechanical properties

See table about Max live load and Min load bearing capacity and Functional demands, Mechanical properties at www.ecophon.com.



CE

Ecophon ceiling systems are CE marked according to the European harmonized standard EN 13964:2014. CE marked construction products are covered by a Declaration of Performance (DOP) which enables customers and users to easily compare performance of products available on the European market.

INSTALLATION DIAGRAM (M122) FOR ECOPHON ADVANTAGE E

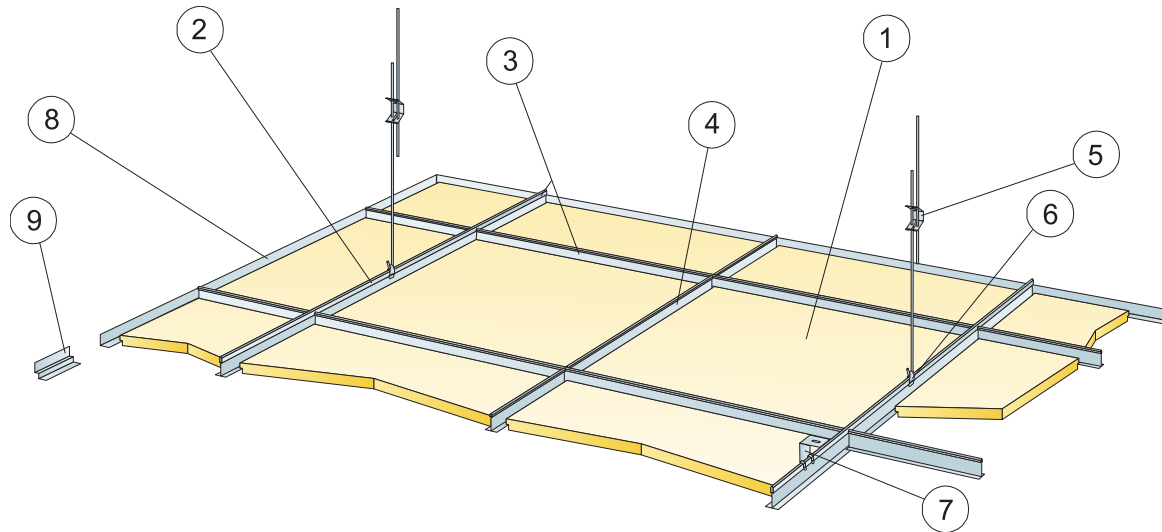

© Ecophon Group

QUANTITY SPECIFICATION (EXCL. WASTAGE)

	Size, mm	
	600x600	1200x600
1 Advantage E	2,8/m ²	1,4/m ²
2 Connect T24 or T15 Main runner, installed at 1200 mm centres (max. distance from wall 600 mm, can be extended up to 1200 mm if no live load between Main 0,9m/m ² runner and wall).	0,9m/m ²	0,9m/m ²
3 Connect T24 or T15 Cross tee, L=1200 mm, installed at 600 mm centres	1,7m/m ²	1,7m/m ²
4 Connect T24 or T15 Cross tee, L=600 mm	0,9m/m ²	-
5 Connect Adjustable Hanger, installed at 1200 mm centres (max. distance from wall 600 mm)	0,7/m ²	0,7/m ²
6 Connect Hanger Clip (not to be used in swimming hall environments)	0,7/m ²	0,7/m ²
7 For direct installation: Connect Direct Bracket, installed at 1200 mm centres	0,7/m ²	0,7/m ²
8 Connect Angle Trim, fixed at 300 mm centres	as required	as required
9 Connect Shadow-line Trim, fixed at 300 mm centres	as required	as required
Δ Min. overall depth of system, with adjustable hanger: 110 mm, with direct bracket: 60 mm	-	-
δ Min. demounting depth: T15: 110 mm, T24: 90 mm	-	-
For luminaire integration in panels use Connect Bridging	-	-

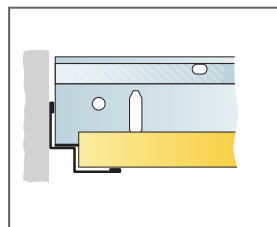
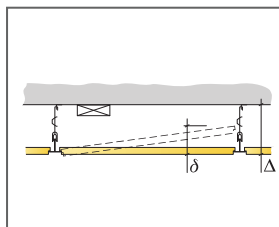

Straight cut, panel resting on shadow-line trim.

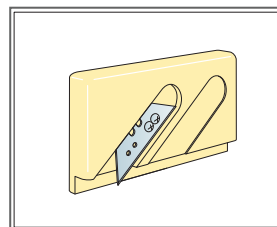

Cutting tool E

Size, mm	Max live load [N]	Min load bearing capacity [N]
600x600x15	50	160
1200x600x15	50	160

Live load/load bearing capacity

INSTALLATION DIAGRAM (M272) FOR ECOPHON ADVANTAGE E, CONNECT T24 MAIN RUNNER INSTALLED AT 1800 MM CENTRES

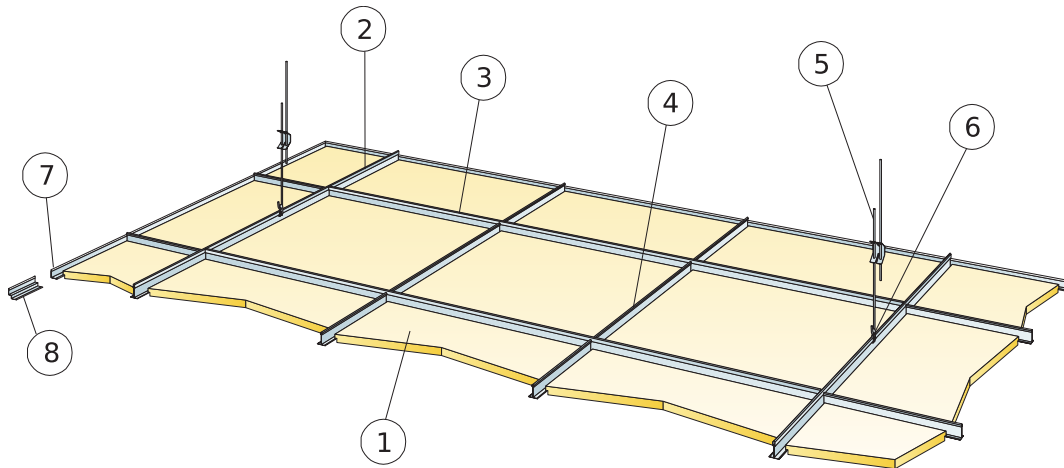

© Ecophon Group

QUANTITY SPECIFICATION (EXCL. WASTAGE)

	Size, mm
	600x600
1 Advantage E	2,8/m ²
2 Connect T24 Main runner, installed at 1800 mm centres (max. distance from wall 600 mm, can be extended up to 1200 mm if no live load between Main runner and wall).	0,56/m ²
3 Connect T24 Cross tee, L=1800 mm	1,7m/m ²
4 Connect T24 Cross tee, L=600 mm	1,1m/m ²
5 Connect Adjustable hanger, installed at 1200 mm centres (max. distance from wall 600 mm)	0,46/m ²
6 Connect Hanger clip	0,46/m ²
7 Connect Angle trim, fixed at 300 mm centres	as required
8 Alt. Connect Shadow-line Trim, fixed c300	as required
Δ Min. overall depth of system, with adjustable hanger: 100 mm, with direct bracket: 50 mm	-
δ Min. demounting depth: 120 mm	-
For luminaire integration in panels use Connect Bridging	-

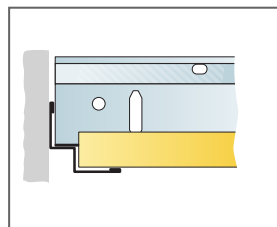
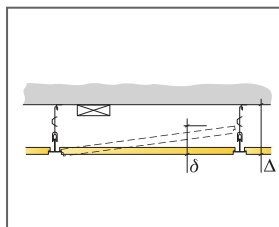

Straight cut, panel resting on shadow-line trim.

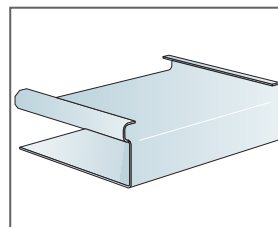

Connect E-plug

Size, mm	Max live load [N]	Min load bearing capacity [N]
600x600x15	20	160

Live load/load bearing capacity