

Ecophon Access™ A

Ecophon Access™ A has an exposed frame system. Each tile has a hatch functionality making the installations above ceiling very easy to access.

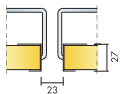

SYSTEM RANGE



Size, mm	2000x577	2000x1177
Special Fixing	•	•
Thickness	27	27
Inst. Diagr.	M60	M60

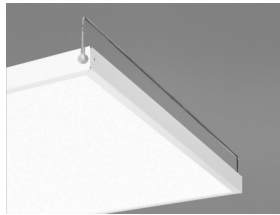

Access A panel

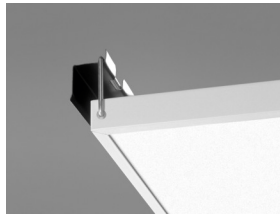

Integration between wall and Access A with Access Universal profile

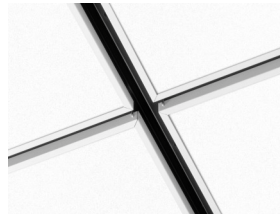

Access A system

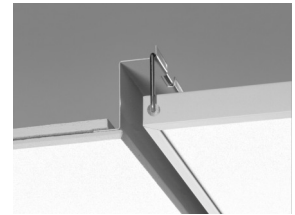

Access A system with Access Frieze

Acoustic



Sound Absorption:

Test results according to EN ISO 354. Classification according to EN ISO 11654, and the single value ratings for Noise Reduction Coefficient, NRC and Sound Absorption Average, SAA according to ASTM C 423.

α_p , Practical sound absorption coefficient

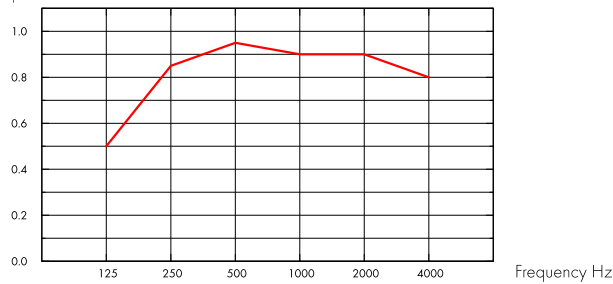

— Access A 25 mm, 200 mm o.d.s.
o.d.s = overall depth of system

THK mm	o.d.s. mm	α_p , Practical sound absorption coefficient						α_w	Sound absorption class
		125 Hz	250 Hz	500 Hz	1000 Hz	2000 Hz	4000 Hz		
25	200	0.50	0.85	0.95	0.90	0.90	0.80	0.90	A

THK mm	o.d.s. mm	NRC	SAA
25	200	1.00	0.96

Indoor Air Quality



Certificate / Label	
Eurofins Indoor Air Comfort®	IAC Gold
French VOC	A+



Circularity



Minimum post-consumer recycled content	57%*
Recyclability	Fully recyclable

*Access frame and accessories excluded

Fire safety



Country	Fire standard	Class
Europe	EN 13501-1	A2-s1,d0

The glass wool core of the tiles is tested and classified as non-combustible according to EN ISO 1182.

Humidity Resistance



Class C, relative humidity 95% and 30°C, according to EN 13964:2014



Visual appearance

White Frost, nearest NCS colour sample S 0500-N, 85% light reflectance. Gloss < 1.



Cleanability

Daily dusting and vacuum cleaning. Weekly wet wiping.



Accessibility

The tiles are easily demountable. Minimum demounting depth according to installation diagrams.



Installation

Installed according to installation diagrams, installation guides and drawing aid. For information regarding minimum overall depth of system see quantity specification.



System weight

The weight of the system (including suspension grid) should be approximately 4 kg/m².



Mechanical properties

See table about Max live load and Min load bearing capacity and Functional demands, Mechanical properties at www.ecophon.com.



CE

Ecophon ceiling systems are CE marked according to the European harmonized standard EN13964:2014. CE marked construction products are covered by a Declaration of Performance (DOP) which enables customers and users to easily compare performance of products available on the European market.

INSTALLATION DIAGRAM (M60) FOR ECOPHON ACCESS A

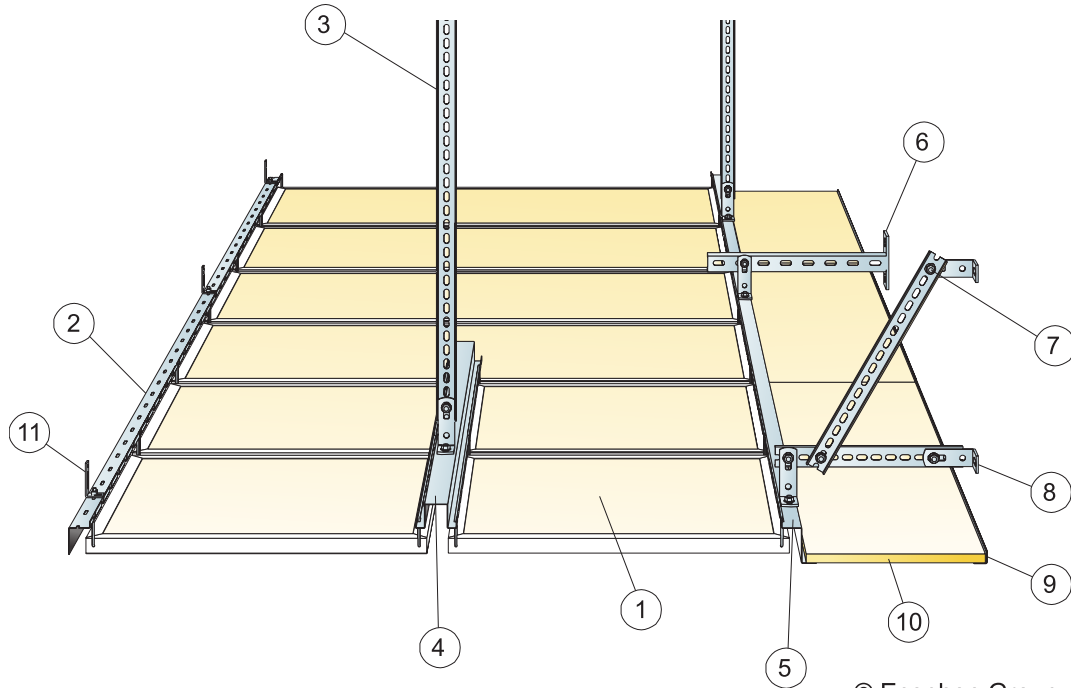

© Ecophon Group

QUANTITY SPECIFICATION (EXCL. WASTAGE)

	Size, mm	
	2000x577	2000x1177
1 Access A	as required	as required
2 Access Universal profile	as required	as required
3 Access Suspension bar	as required	as required
4 Access Double carrier profile	as required	as required
5 Access Transition profile	as required	as required
6 Access Wall bracket alt. Access Ceiling bracket	as required	as required
7 Access Installation screw	as required	as required
8 Access Angle bracket	as required	as required
9 Connect Angle trim, fixed at 300 mm centres	as required	as required
10 Access Frieze panel (for installation see IG144)	as required	as required
11 Access Wall fixing plate	as required	as required
Δ Min. overall depth of system: 120 mm	-	-
δ Min. demounting depth: 80 mm	-	-

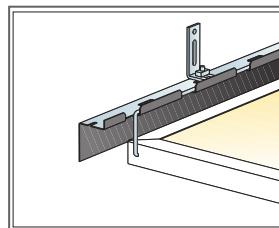
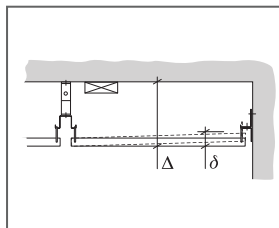

Junction with wall

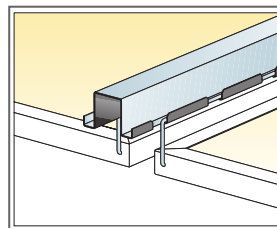

Access Double carrier profile with multiple rows of panels

Size, mm	Max live load [N]	Min load bearing capacity [N]
2000x577x27	60	220
2000x1177x27	30	220

Live load/load bearing capacity

Ecophon Access™ C

Ecophon Access™ C has a concealed frame system.
Each tile has a hatch functionality making the installations above ceiling very easy to access.



Syddansk universitet, Odense, Denmark

SYSTEM RANGE

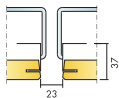

Size, mm	2000x577	2000x1177
Special Fixing	•	•
Thickness	37	37
Inst. Diag.	M63	M63

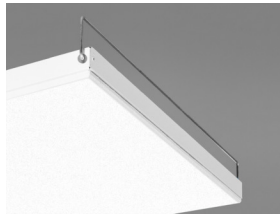

Access C panel

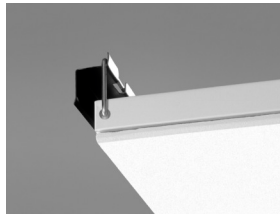

Integration between wall and Access C with Access Universal profile

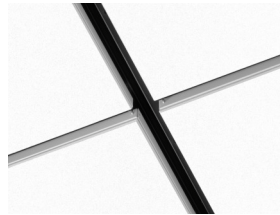

Access C system

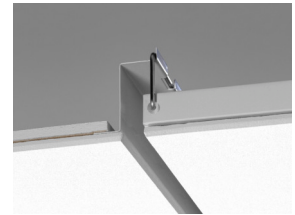

Access C system with Access frieze

Acoustic



Sound Absorption:

Test results according to EN ISO 354. Classification according to EN ISO 11654, and the single value ratings for Noise Reduction Coefficient, NRC and Sound Absorption Average, SAA according to ASTM C 423.

α_p , Practical sound absorption coefficient

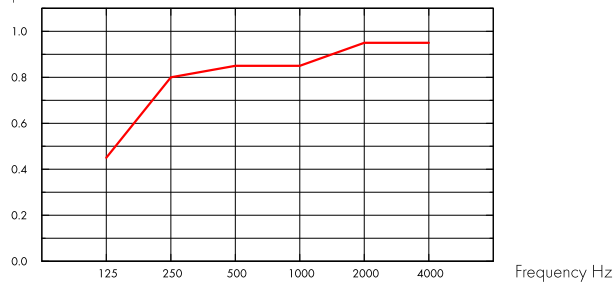

— Access C 20 mm, 200 mm o.d.s.
o.d.s = overall depth of system

THK mm	o.d.s. mm	α_p , Practical sound absorption coefficient						α_w	Sound absorption class
		125 Hz	250 Hz	500 Hz	1000 Hz	2000 Hz	4000 Hz		
20	200	0.45	0.80	0.85	0.85	0.95	0.95	0.90	A

THK mm	o.d.s. mm	NRC	SAA
20	200	0.90	0.87

Indoor Air Quality



Certificate / Label	
Eurofins Indoor Air Comfort®	IAC Gold
French VOC	A+



Circularity



Minimum post-consumer recycled content	52%*
Recyclability	Fully recyclable

*Access frame and accessories excluded

Fire safety



Country	Fire standard	Class
Europe	EN 13501-1	A2-s1,d0

The glass wool core of the tiles is tested and classified as non-combustible according to EN ISO 1182.

Humidity Resistance



Class C, relative humidity 95% and 30°C, according to EN 13964:2014



Visual appearance

White Frost, nearest NCS colour sample S 0500-N, 85% light reflectance. Gloss < 1.



Cleanability

Daily dusting and vacuum cleaning. Weekly wet wiping.



Accessibility

The tiles are easily demountable. Minimum demounting depth according to installation diagrams.



Installation

Installed according to installation diagrams, installation guides and drawing aid. For information regarding minimum overall depth of system see quantity specification.



System weight

The weight of the system (including suspension grid) should be approximately 4 kg/m².



Mechanical properties

See table about Max live load and Min load bearing capacity and Functional demands, Mechanical properties at www.ecophon.com.



CE

Ecophon ceiling systems are CE marked according to the European harmonized standard EN13964:2014. CE marked construction products are covered by a Declaration of Performance (DOP) which enables customers and users to easily compare performance of products available on the European market.

INSTALLATION DIAGRAM (M63) FOR ECOPHON ACCESS C

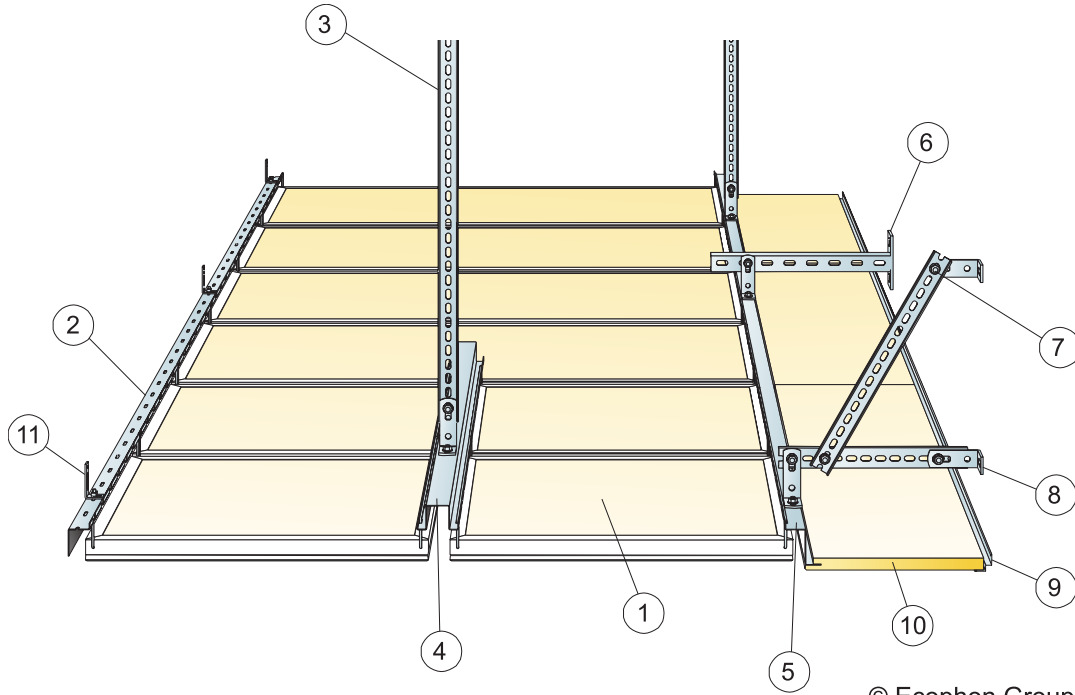

© Ecophon Group

QUANTITY SPECIFICATION (EXCL. WASTAGE)

	Size, mm	
	2000x577	2000x1177
1 Access C	as required	as required
2 Access Universal profile	as required	as required
3 Access Suspension bar	as required	as required
4 Access Double carrier profile	as required	as required
5 Access Transition profile	as required	as required
6 Access Wall bracket alt. Access Ceiling bracket	as required	as required
7 Access Installation screw	as required	as required
8 Access Angle bracket	as required	as required
9 Connect Angle trim, fixed at 300 mm centres	as required	as required
10 Access Frieze panel (for installation see IG144)	as required	as required
11 Access Wall fixing plate	as required	as required
Δ Min. overall depth of system: 130 mm	-	-
δ Min. demounting depth: 90 mm	-	-

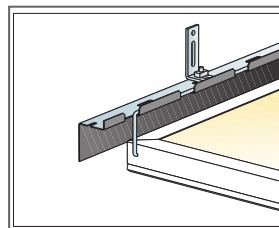
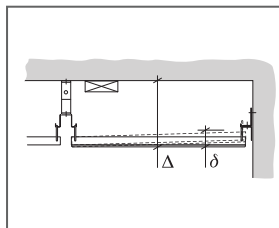

Junction with wall

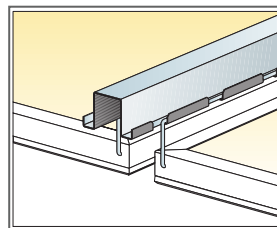

Carrier profile for more than one row of Access panels.

Size, mm	Max live load [N]	Min load bearing capacity [N]
2000x577x37	60	220
2000x1177x37	30	220

Live load/load bearing capacity

Ecophon Access™ Frieze

For applications where a smooth continuous transition between the ceiling and the wall is needed. The Access frieze is developed for installation together with Ecophon Access™ panels. The frieze is connected to the wall without any visible trims. The bevelled edges create a narrow groove between each tile. The tiles are not demountable.



Ecophon Head Office, Hylinge, Sweden

SYSTEM RANGE

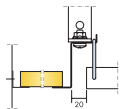

Size, mm	2400x600
Special Fixing	•
Thickness	20
Inst. Diag.	M114

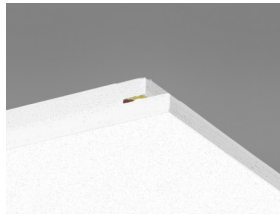

Access frieze tile

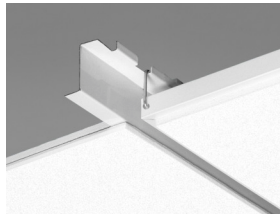

Access frieze system

Acoustic



Sound Absorption:

Test results according to EN ISO 354. Classification according to EN ISO 11654, and the single value ratings for Noise Reduction Coefficient, NRC and Sound Absorption Average, SAA according to ASTM C 423.

α_p , Practical sound absorption coefficient

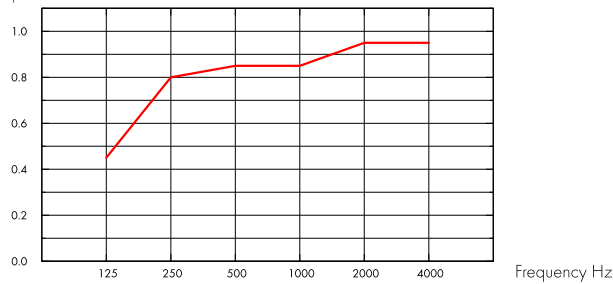

— Access Frieze 20 mm, 200 mm o.d.s.
o.d.s = overall depth of system

THK mm	o.d.s. mm	α_p , Practical sound absorption coefficient						α_w	Sound absorption class
		125 Hz	250 Hz	500 Hz	1000 Hz	2000 Hz	4000 Hz		
20	200	0.45	0.80	0.85	0.85	0.95	0.95	0.90	A



Indoor Air Quality

Certificate / Label

Eurofins Indoor Air Comfort®

IAC Gold

French VOC

A+



Fire safety

Country	Fire standard	Class
Europe	EN 13501-1	A2-s1,d0

The glass wool core of the tiles is tested and classified as non-combustible according to EN ISO 1182.



Humidity Resistance

Class C, relative humidity 95% and 30°C, according to EN 13964:2014



Visual appearance

White Frost, nearest NCS colour sample S 0500-N, 85% light reflectance. Gloss < 1.



Cleanability

Daily dusting and vacuum cleaning. Weekly wet wiping.



Accessibility

The tiles are non-demountable.



Installation

Installed according to installation diagrams, installation guides and drawing aid. For information regarding minimum overall depth of system see quantity specification.



Mechanical properties

See table about Max live load and Min load bearing capacity and Functional demands, Mechanical properties at www.ecophon.com.



CE

Ecophon ceiling systems are CE marked according to the European harmonized standard EN 13964:2014. CE marked construction products are covered by a Declaration of Performance (DOP) which enables customers and users to easily compare performance of products available on the European market.

INSTALLATION DIAGRAM (M114) FOR ECOPHON ACCESS FRIEZE

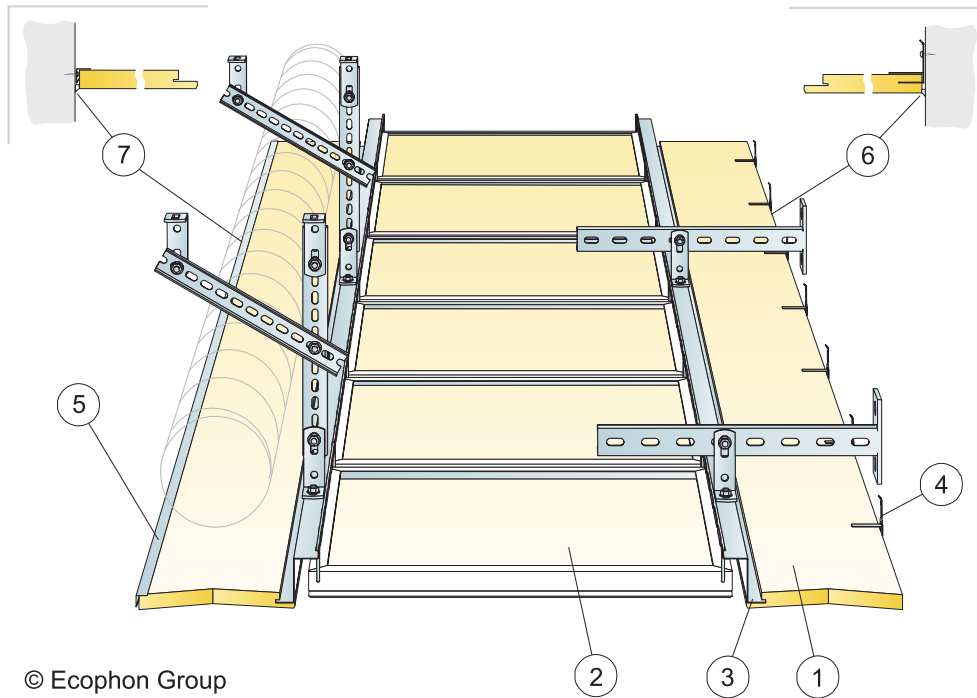

© Ecophon Group

QUANTITY SPECIFICATION (EXCL. WASTAGE)

	Size, mm
	2400x600
1 Access frieze	as required
2 Access panel	as required
3 Access Transition profile O151	as required
4 Connect Frieze bracket 0043, installed at maximum 500 mm centre. Minimum free depth above tile 150 mm.	as required
5 Connect Frieze trim 0562, fixed at 300 mm centres. Minimum free depth above tile 0 mm	as required
6 Connect frieze bracket 0043 with acrylic sealant	as required
7 Connect frieze trim with acrylic sealant (sealant not supplied by Ecophon)	as required
Δ Min. overall depth of system: See Installation diagram M60, M63 and M64	
δ Min. demounting depth: The system is non-demountable	
Access frieze: can be divided in two parts if width is less than 300 mm	

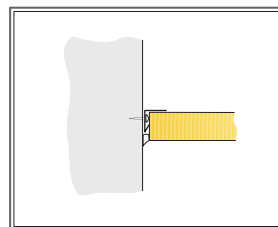
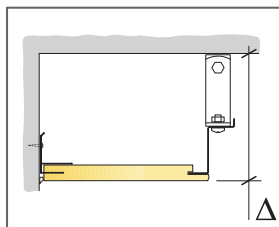

Fixing with frieze trim

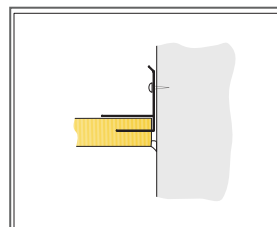

Fixing with frieze bracket

Size, mm	Max live load [N]	Min load bearing capacity [N]
2400x600x20	0	160

Live load/load bearing capacity