

Hygiene Lavanda™ LED

A recessed modular luminaire for use in Ecophon Hygiene ceilings. Hygiene Lavanda LED is equipped with a high frequency ballast, is flush mounted in the ceiling to avoid pockets that could accumulate dirt and dust and can withstand low pressure washing.



Centre Hospitalier Universitaire de Lille, Lille, France

SYSTEM RANGE

 Size, mm	600x600
T24	•
Thickness (THK)	75
Inst. Diag.	M429



Hygiene Lavanda LED



Lighting performance

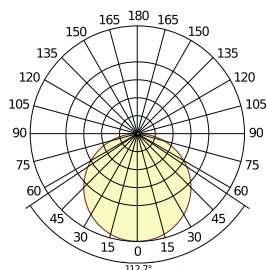

System effect: 49,8 W
Light source: LED
Luminous flux: 4189 lm
Light efficiency: 84 lm/W
Colour temperature: 4000K
Color rendering index: Ra >80
Colour tolerance: MacAdam 3 SDCM
Light output ratio (LOR): 100%
Light distribution up/down: 0/100
Expected lifespan: L80 >60000 h



Electrical data

230-240V, 50 Hz, power factor $\cos \phi > 0,95$. Electronic HF ballast.



Connection

Delivered without any cables. Can be installed for on/off, SwitchDIM or DALI.



Electrical approvals

IP65, Class 1.



Cleanability

Daily dusting, vacuum cleaning, manual wet cleaning and low-pressure washing. Water temperature max. 70°C. Can withstand the use of common disinfecting chemicals.



Installation

Installed according to installation diagrams, installation guides and drawing aid. For information regarding minimum overall depth of system see quantity specification.

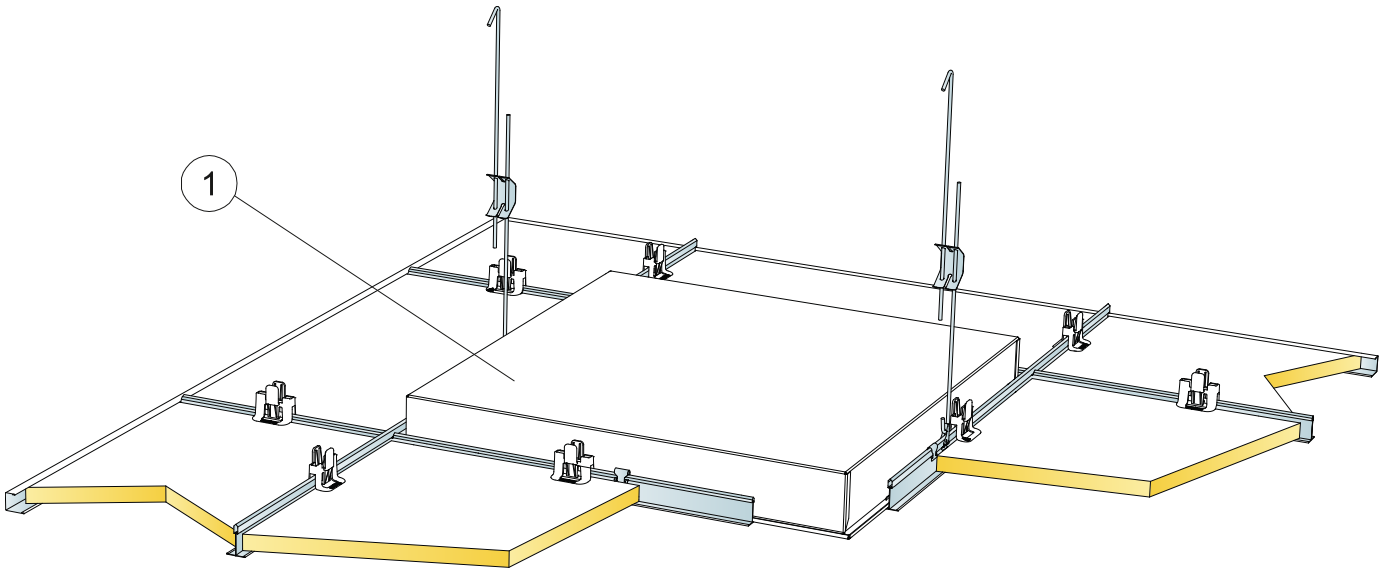

© Saint-Gobain Ecophon AB

QUANTITY SPECIFICATION (EXCL. WASTAGE)

		Size, mm
		600x600
1	Hygiene Lavanda LED	as required
	δ Min. demounting depth: 300 mm	-

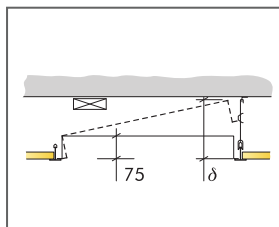

See Quantity Specification

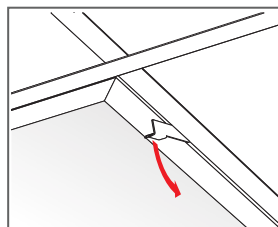

Opening of the frame, which is secured with a snap-lock device

Size, mm	Max live load (N)	Min load bearing capacity (N)
600x600x75	0	160

Live load/load bearing capacity

Ecophon Dot™

Ecophon Dot™ is a fully integrated recessed luminaire, shaped as a circle. Solution available for Focus Dg, Ds, E, Ez and Master Eg. The slim design of the luminaire makes the installation height low. The ballast is available as on/off and dimmable version. The louvre is designed for office environments.

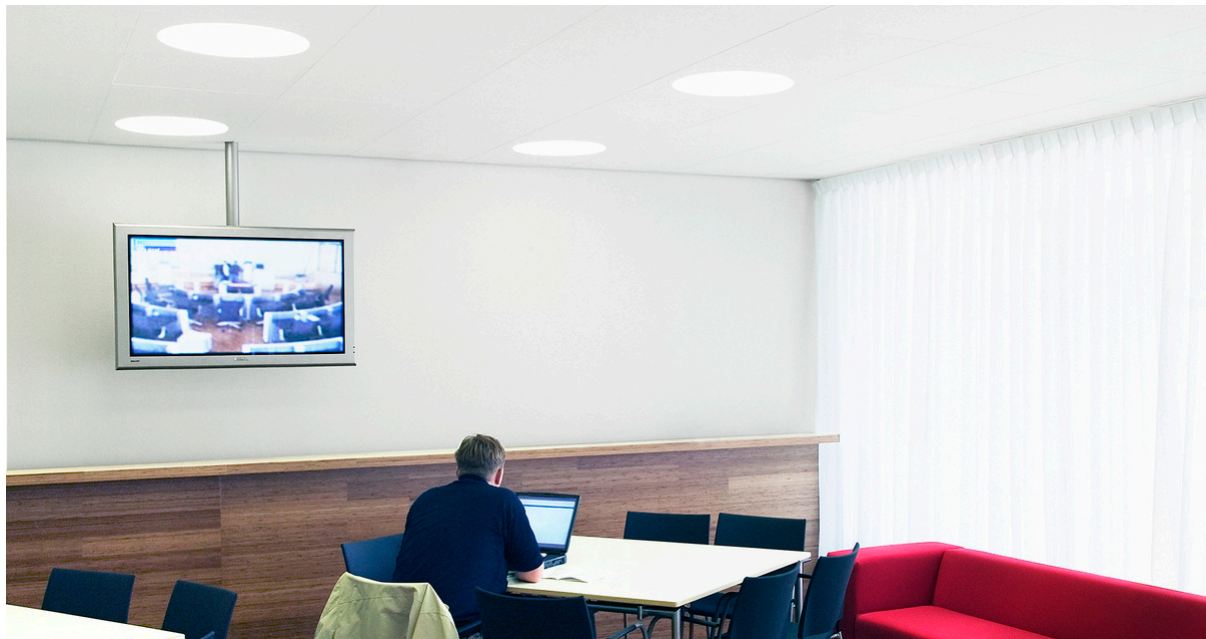

Zoetermeer, City Hall of Zoetermeer, Netherlands

SYSTEM RANGE

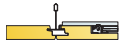

Size, mm	600x600	600x600
T24	•	•
Thickness (THK)	20	40
Inst. Diagr.	M516, M518	M516, M518

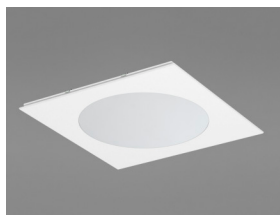

Ecophon Dot LED Ds tile

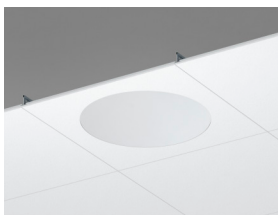

Ecophon Dot LED Ds section

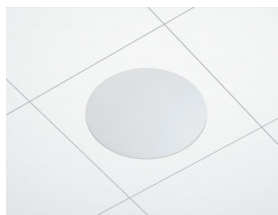

Ecophon Square LED Ds system



Lighting performance

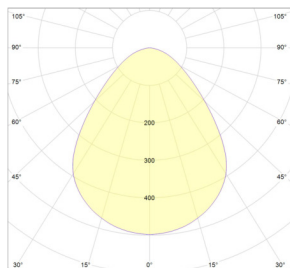

System effect Dot: 27 W

Light source: LED 24,5 W

Luminous flux Dot Dg, Ds, E: 2936 lm

Luminous flux Dot Eg, Ez: 2635 lm

Light efficiency Dot Dg, Ds, E: 108,7 lm/W

Light efficiency Dot Eg, Ez: 99 lm/W

Colour temperature: 4000K

Color rendering index: Ra \geq 80

Colour tolerance: MacAdam \leq 3 SDCM

Light output ratio (LOR): 100%

Light distribution up/down: 0/100

Expected lifespan: L90 >50 000 h

Expected lifespan: L70 >100 000 h



Connection

The standard on/off electronic HF ballast delivered with 2,5 meters of cable 3x0,75 mm² and Euro plugg. The SwitchDIM/DALI delivered without cable.



Electrical data

220-240 V, 50-60 Hz, power factor $\cos \phi > 0,98$. Electronic HF ballast or electronic HF dim ballast for digital regulation. Light source: led module of 27W total.



Electrical approvals

IP20, Class 1.



Visual appearance

Tile surface finish; White Frost, nearest NCS colour sample S 0500-N, 85% light reflectance. Gloss < 1.



Cleanability

Daily dusting and vacuum cleaning. Weekly wet wiping.



Accessibility

The tiles are easily demountable. Minimum demounting depth according to installation diagrams.



Installation

Installed according to system range which include information regarding minimum overall depth of system. The tile with luminaire housing rests on the T-profiles and the SwitchDIM/DALI and standard on/off ballasts are fastened to the grid or tile next to the luminaire with velcro. Once the tile with luminaire and ballast are in place a certified installation electrician must connect the wiring to sockets or to the next luminaire.

INSTALLATION DIAGRAM (M516) FOR ECOPHON DOT LED DS

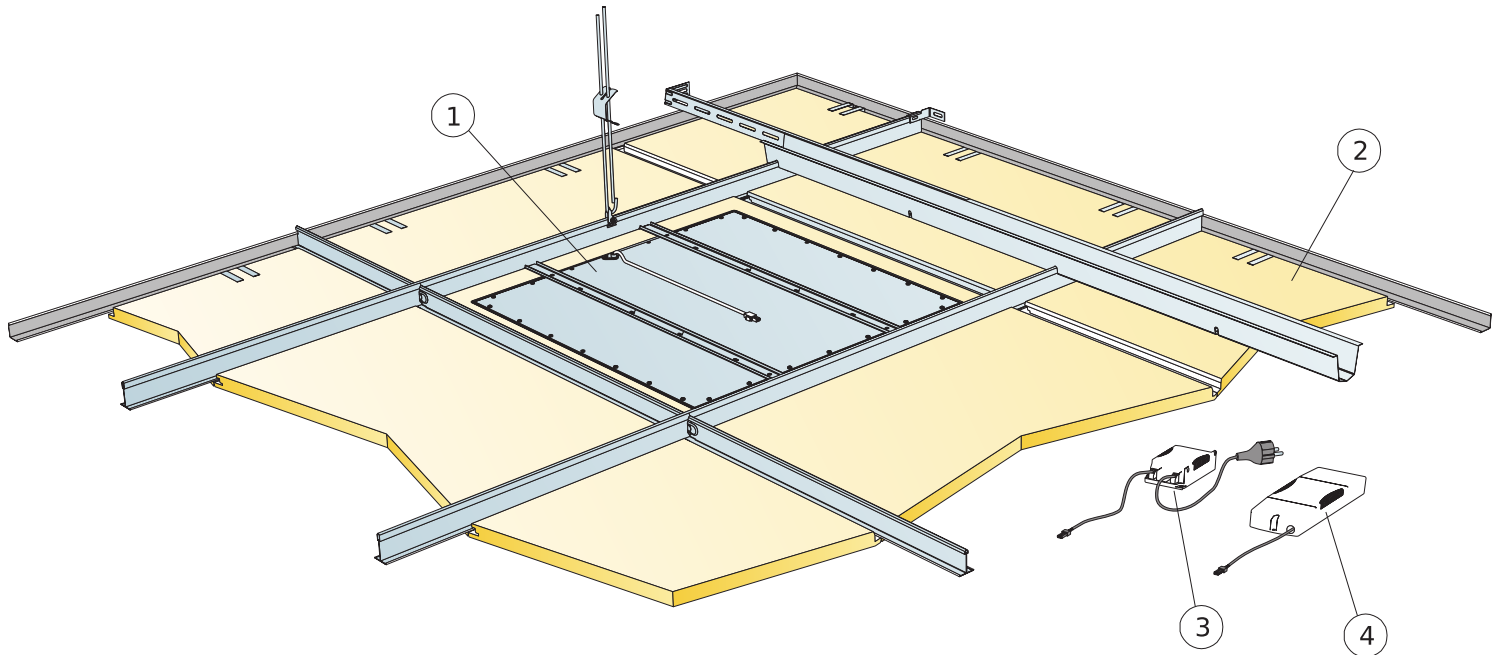

© Ecophon Group

QUANTITY SPECIFICATION (EXCL. WASTAGE)

	Size, mm
	600x600
1 Ecophon Dot/Square LED Ds Kit	1/luminaire
2 Focus Ds [adjacent ceiling]	as required
3 Ecophon Dot/Square/Line standard On/Off Ballast (included) [Alt.1]	-
4 Ecophon Dot/Square/Line SwitchDIM/DALI Ballast (included) [Alt.2]	-
Δ Min. overall depth of system: 115 mm	-
δ Min. demounting depth: 50 mm	-
When selecting standard on/off ballast, connect only to a toggle power switch. When using the SwitchDIM/DALI ballast connecting the SwitchDIM function, use a spring loaded power switch.	-
When selecting the SwitchDIM/DALI ballast utilizing the DALI function, connect only to a DALI compatible controller.	-

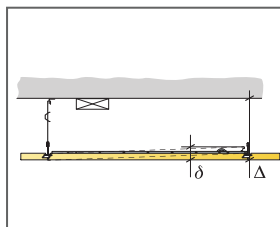

See Quantity Specification

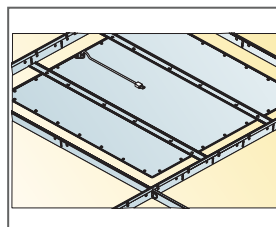

Dot Ds luminaire house resting on main runner

Size, mm	Max live load (N)	Min load bearing capacity (N)
600x600x20	0	160
600x600x40	0	160

Live load/load bearing capacity

INSTALLATION DIAGRAM (M518) FOR ECOPHON DOT LED DG, E, EG AND EZ

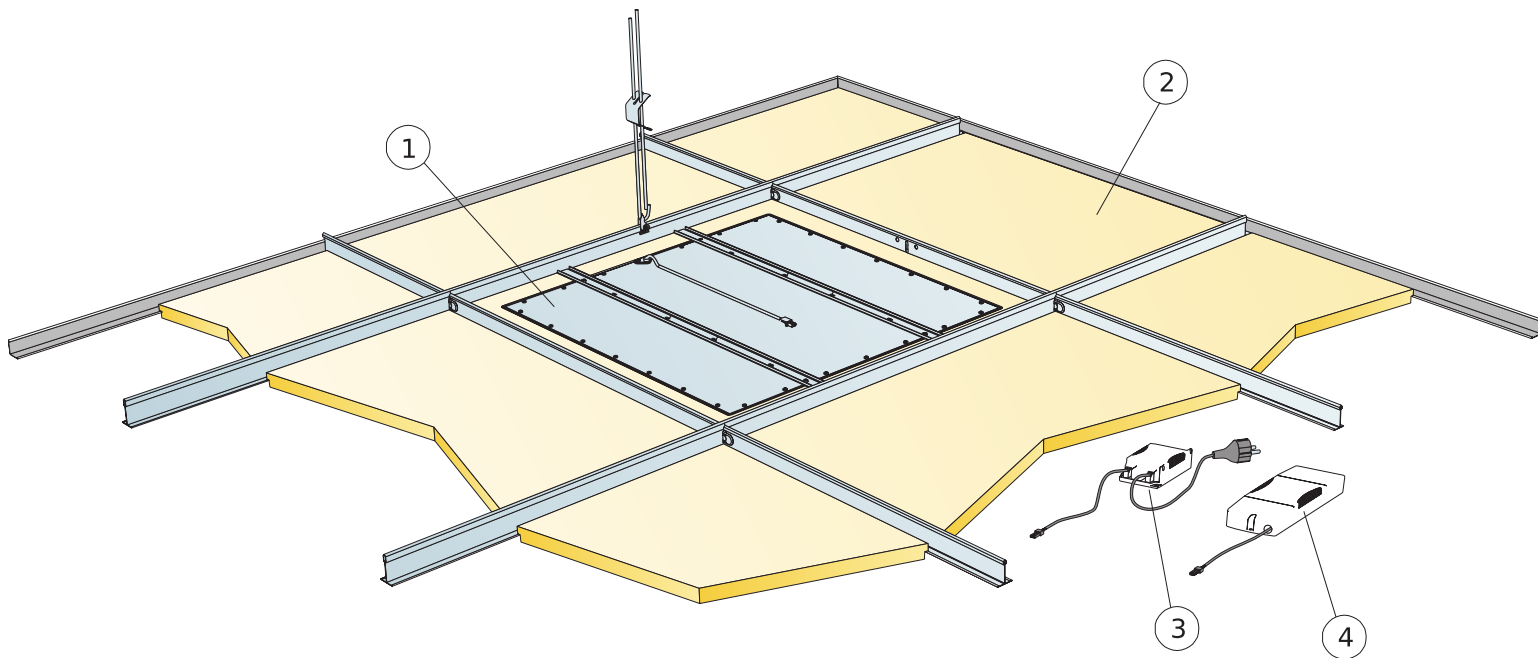

© Ecophon Group

QUANTITY SPECIFICATION (EXCL. WASTAGE)

	Size, mm
	600x600
1 Ecophon Dot/Square LED Dg, E, Eg or Ez Kit	1/luminaire
2 Focus Dg, E, Eg or Ez T24 (adjacent ceiling)	as required
3 Ecophon Dot/Square/Line standard On/Off Ballast (included) (Alt.1)	-
4 Ecophon Dot/Square/Line SwitchDIM/DALI Ballast (included) (Alt.2)	-
Δ Min. overall depth of system: 115 mm	-
δ Min. demounting depth: 50 mm	-
When selecting standard on/off ballast, connect only to a toggle power switch. When using the SwitchDIM/DALI ballast connecting the SwitchDIM function, use a spring loaded power switch.	-
When selecting the SwitchDIM/DALI ballast utilizing the DALI function, connect only to a DALI compatible controller.	-

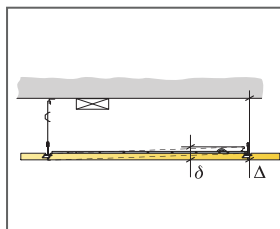

See Quantity Specification

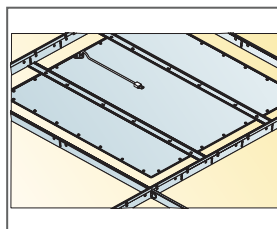

Dot Dg, E, Eg and Ez luminaire house resting on main runner

Size, mm	Max live load (N)	Min load bearing capacity (N)
600x600x20	0	160
600x600x40	0	160

Live load/load bearing capacity

Ecophon Line™

Ecophon Line™ is a fully integrated recessed luminaire, shaped as a narrow rectangle. The slim design of the luminaire makes the installation height low. The ballast is available as on/off and dimmable version. The louvre is designed to be a general light source in open spaces and walkways.



SYSTEM RANGE

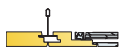

Size, mm	1200x150	1200x300	1200x600
T24	•	•	•
Thickness (THK)	20	20	20
Inst. Diagr.	M520	M520	M517, M519

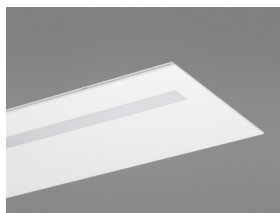

Ecophon Line LED Ds tile

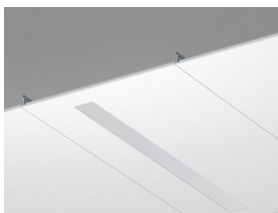

Ecophon Line LED Ds section

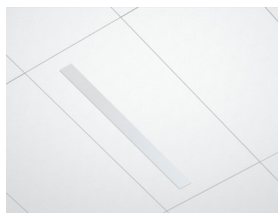

Ecophon Line LED Ds system



Lighting performance

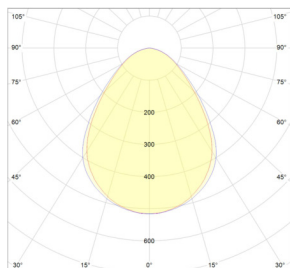

System effect: 29,4W
 Light source: LED 26,7 W
 Luminous flux: 2337 lm
 Light efficiency: 87,5 lm/W
 Colour temperature: 4000K
 Color rendering index: Ra ≥80
 Colour tolerance: MacAdam ≤3 SDCM
 Light output ratio (LOR): 100%
 Light distribution up/down: 0/100
 Expected lifespan: L90 >50 000 h
 Expected lifespan: L70 >100 000 h



Connection

The standard on/off electronic HF ballast delivered with 2,5 meters of cable 3x0,75 mm² and Euro plugg. The SwitchDIM/DALI delivered without cable.



Electrical data

220-240 V, 50-60 Hz, power factor $\cos \phi > 0,98$. Electronic HF ballast or electronic HF dim ballast for digital regulation.
 Light source: led module of 27W total.



Electrical approvals

IP20, Class 1.



Visual appearance

Tile surface finish; White Frost, nearest NCS colour sample S 0500-N, 85% light reflectance. Gloss < 1.



Cleanability

Daily dusting and vacuum cleaning. Weekly wet wiping.



Accessibility

The tiles are easily demountable. Minimum demounting depth according to installation diagrams.



Installation

Installed according to system range which include information regarding minimum overall depth of system. The tile with luminaire housing rests on the T-profiles and the SwitchDIM/DALI and standard on/off ballasts are fastened to the grid or tile next to the luminaire with velcro. Once the tile with luminaire and ballast are in place a certified installation electrician must connect the wiring to sockets or to the next luminaire.

INSTALLATION DIAGRAM (M517) FOR ECOPHON LINE LED DS

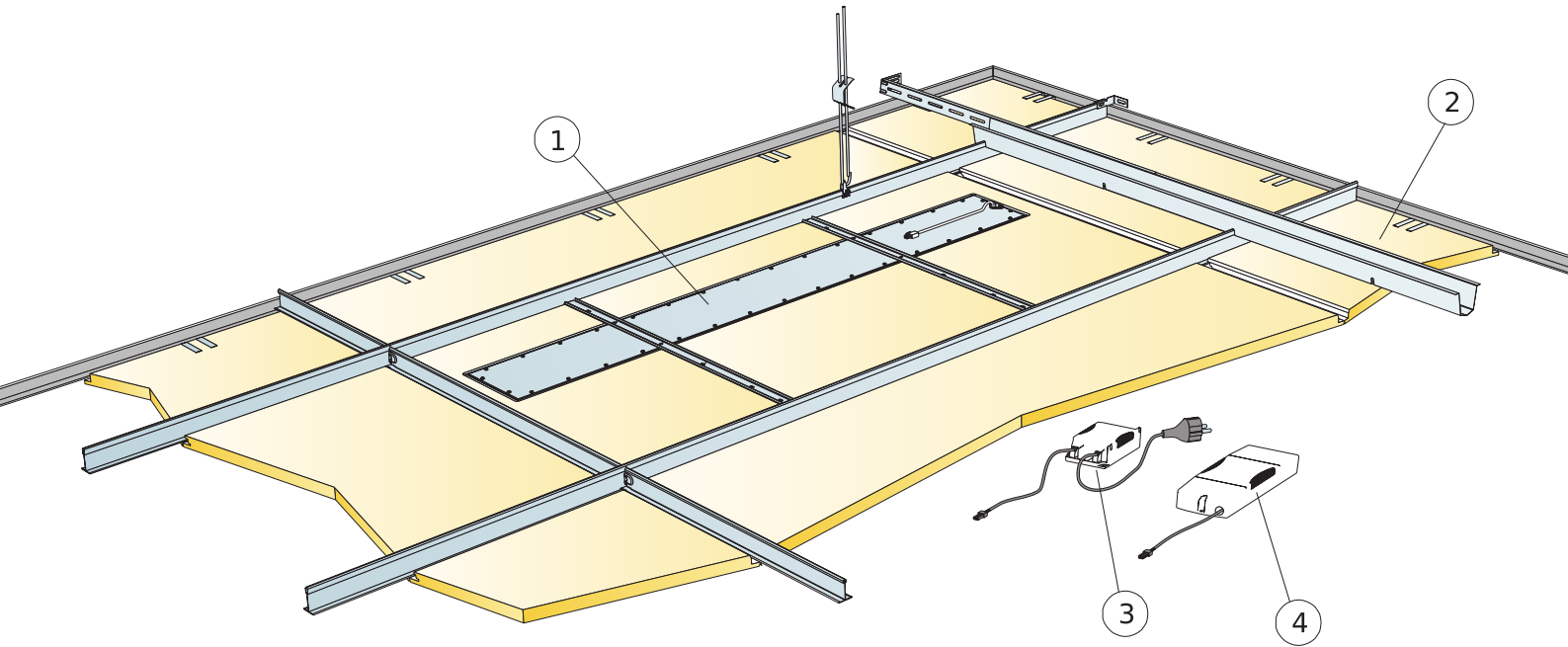

© Ecophon Group

QUANTITY SPECIFICATION (EXCL. WASTAGE)

	Size, mm
	1200x600
1 Ecophon Line LED Ds Kit	1/luminaire
2 Focus Ds [adjacent ceiling]	as required
3 Ecophon Dot/Square/Line standard On/Off Ballast (included) [Alt.1]	-
4 Ecophon Dot/Square/Line SwitchDIM/DALI Ballast (included) [Alt.2]	-
Δ Min. overall depth of system: 115 mm	-
δ Min. demounting depth: 50 mm	-
When selecting standard on/off ballast, connect only to a toggle power switch. When using the SwitchDIM/DALI ballast connecting the SwitchDIM function, use a spring loaded power switch.	-
When selecting the SwitchDIM/DALI ballast utilizing the DALI function, connect only to a DALI compatible controller.	-

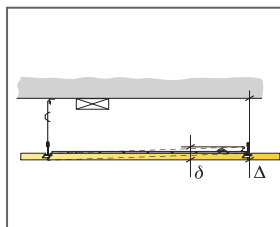

See Quantity Specification

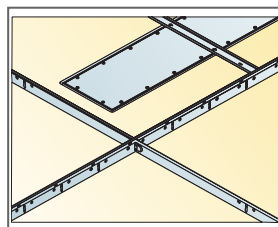

Line Ds luminaire house resting on main runner

Size, mm	Max live load [N]	Min load bearing capacity [N]
1200x600x20	0	160

Live load/load bearing capacity

INSTALLATION DIAGRAM (M519) FOR ECOPHON LINE LED DG AND E

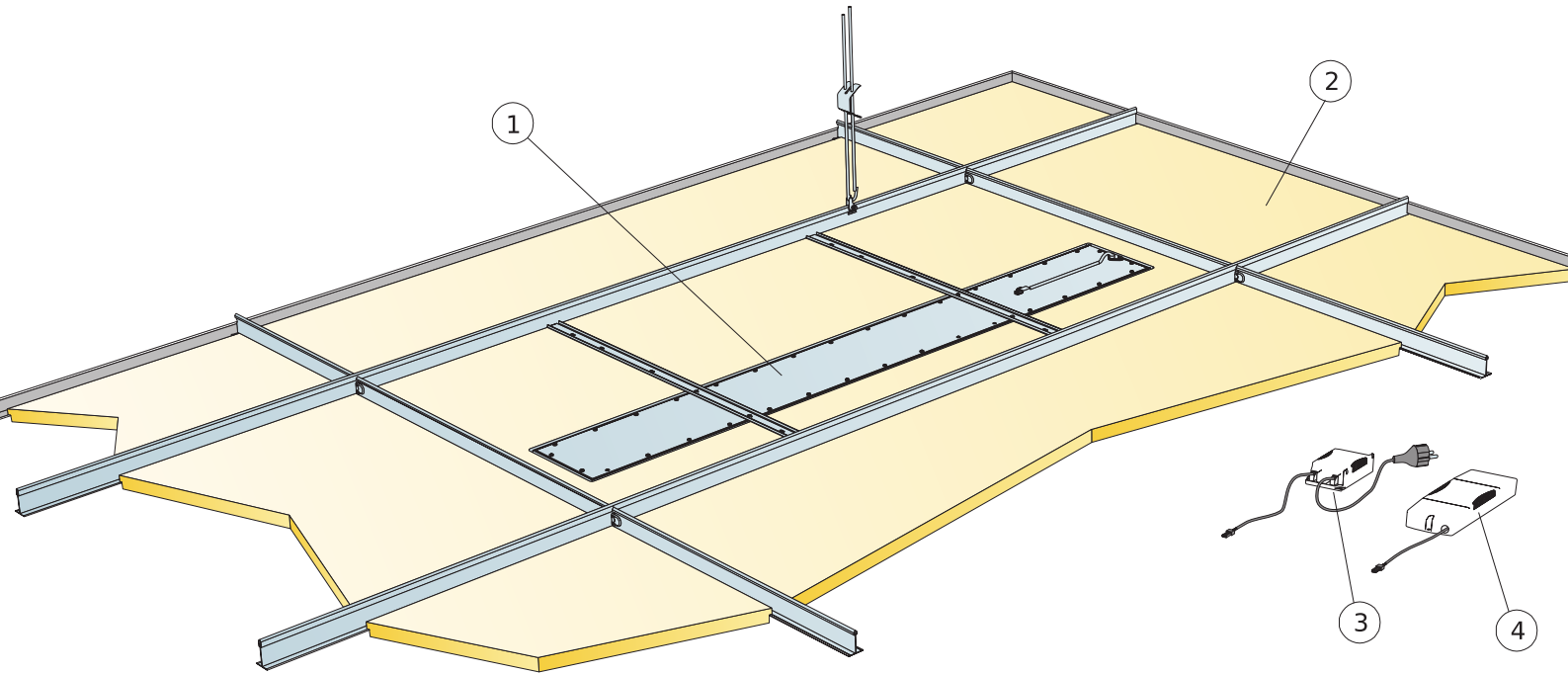

© Ecophon

QUANTITY SPECIFICATION (EXCL. WASTAGE)

	Size, mm
	1200x600
1 Ecophon Line LED Dg or E Kit	1/luminaire
2 Focus Dg or E T24 (adjacent ceiling)	as required
3 Ecophon Dot/Square/Line standard On/Off Ballast (included) (Alt.1)	-
4 Ecophon Dot/Square/Line SwitchDIM/DALI Ballast (included) (Alt.2)	-
Δ Min. overall depth of system: 115 mm	-
δ Min. demounting depth: 50 mm	-
When selecting standard on/off ballast, connect only to a toggle power switch. When using the SwitchDIM/DALI ballast connecting the SwitchDIM function, use a spring loaded power switch.	-
When selecting the SwitchDIM/DALI ballast utilizing the DALI function, connect only to a DALI compatible controller.	-

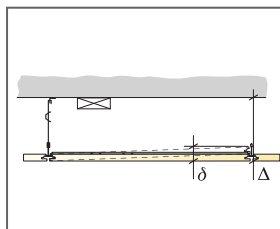

See Quantity Specification

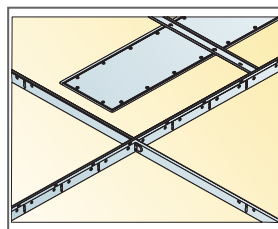

Line Dg and E luminaire house resting on main runner

Size, mm	Max live load [N]	Min load bearing capacity [N]
1200x600x20		160

Live load/load bearing capacity

INSTALLATION DIAGRAM (M520) FOR ECOPHON LINE LED LP

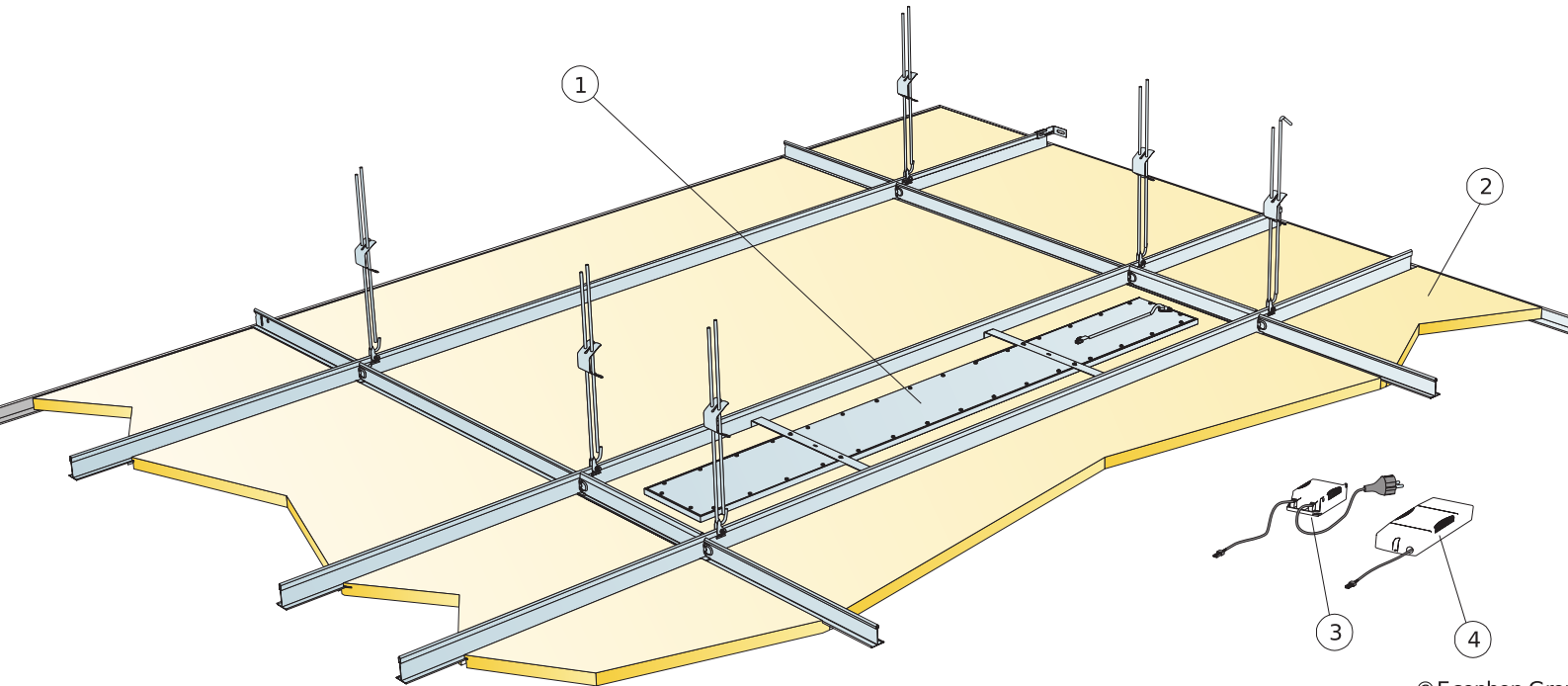

© Ecophon Group

QUANTITY SPECIFICATION (EXCL. WASTAGE)

	Size, mm	
	1200x150	1200x300
1 Ecophon Line LED Lp Kit	1/luminaire	1/luminaire
2 Focus Lp (adjacent ceiling)	as required	as required
3 Ecophon Dot/Square/Line standard On/Off Ballast (included) (Alt.1)	-	-
4 Ecophon Dot/Square/Line SwitchDIM/DALI Ballast (included) (Alt.2)	-	-
Δ Min. overall depth of system: 115 mm	-	-
δ Min. demounting depth: 30 mm	-	-
When selecting standard on/off ballast, connect only to a toggle power switch. When using the SwitchDIM/DALI ballast connecting the SwitchDIM function, use a spring loaded power switch.	-	-
When selecting the SwitchDIM/DALI ballast utilizing the DALI function, connect only to a DALI compatible controller.	-	-

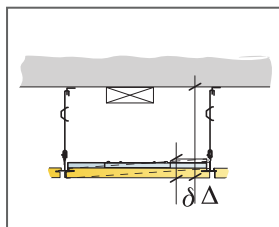

See Quantity specification

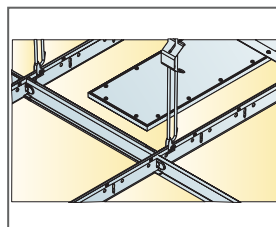

Line Lp luminaire house resting on cross tee

Size, mm	Max live load [N]	Min load bearing capacity [N]
1200x150x20	0	160
1200x300x20	0	160

Live load/load bearing capacity

Ecophon Square 43™

Ecophon Square 43™ is a fully integrated recessed luminaire, shaped as a square. Solution available for Focus Dg, Ds, E, Ez and Master Eg. The slim design of the luminaire makes the installation height low. The ballast is available as on/off and dimmable version. The louvre is designed for office environments.



SYSTEM RANGE

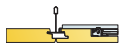

Size, mm	600x600	600x600
T24	•	•
Thickness (THK)	20	40
Inst. Diagr.	M516, M518	M516, M518

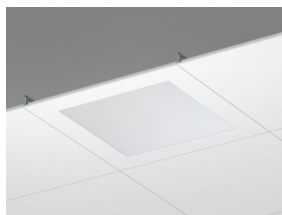

Ecophon Square LED Ds section

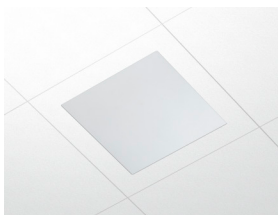

Ecophon Square LED Ds system



Lighting performance

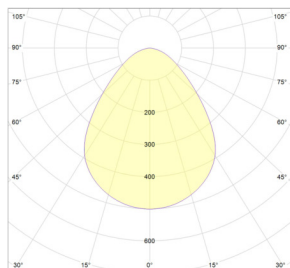

System effect: 27 W
 Light source: LED 24,5 W
 Luminous flux Square Dg, Ds, E: 3281 lm
 Luminous flux Square Eg, Ez: 2898 lm
 Light efficiency Square Dg, Ds, E: 121,4 lm/W
 Light efficiency Square Dg, Ds, E: 108 lm/W
 Colour temperature: 4000K
 Color rendering index: Ra ≥80
 Colour tolerance: MacAdam ≤3 SDCM
 Light output ratio (LOR): 100%
 Light distribution up/down: 0/100
 Expected lifespan: L90 >50 000 h
 Expected lifespan: L70 >100 000 h



Connection

The standard on/off electronic HF ballast delivered with 2,5 meters of cable 3x0,75 mm² and Euro plugg. The SwitchDIM/DALI delivered without cable.



Electrical data

220-240 V, 50-60 Hz, power factor $\cos \phi > 0,98$. Electronic HF ballast or electronic HF dim ballast for digital regulation.
 Light source: led module of 27W total.



Electrical approvals

IP20, Class 1.



Visual appearance

Tile surface finish; White Frost, nearest NCS colour sample S 0500-N, 85% light reflectance. Gloss < 1.



Cleanability

Daily dusting and vacuum cleaning. Weekly wet wiping.



Accessibility

The tiles are easily demountable. Minimum demounting depth according to installation diagrams.



Installation

Installed according to system range which include information regarding minimum overall depth of system. The tile with luminaire housing rests on the T-profiles and the SwitchDIM/DALI and standard on/off ballasts are fastened to the grid or tile next to the luminaire with velcro. Once the tile with luminaire and ballast are in place a certified installation electrician must connect the wiring to sockets or to the next luminaire.

INSTALLATION DIAGRAM (M516) FOR ECOPHON DOT LED DS

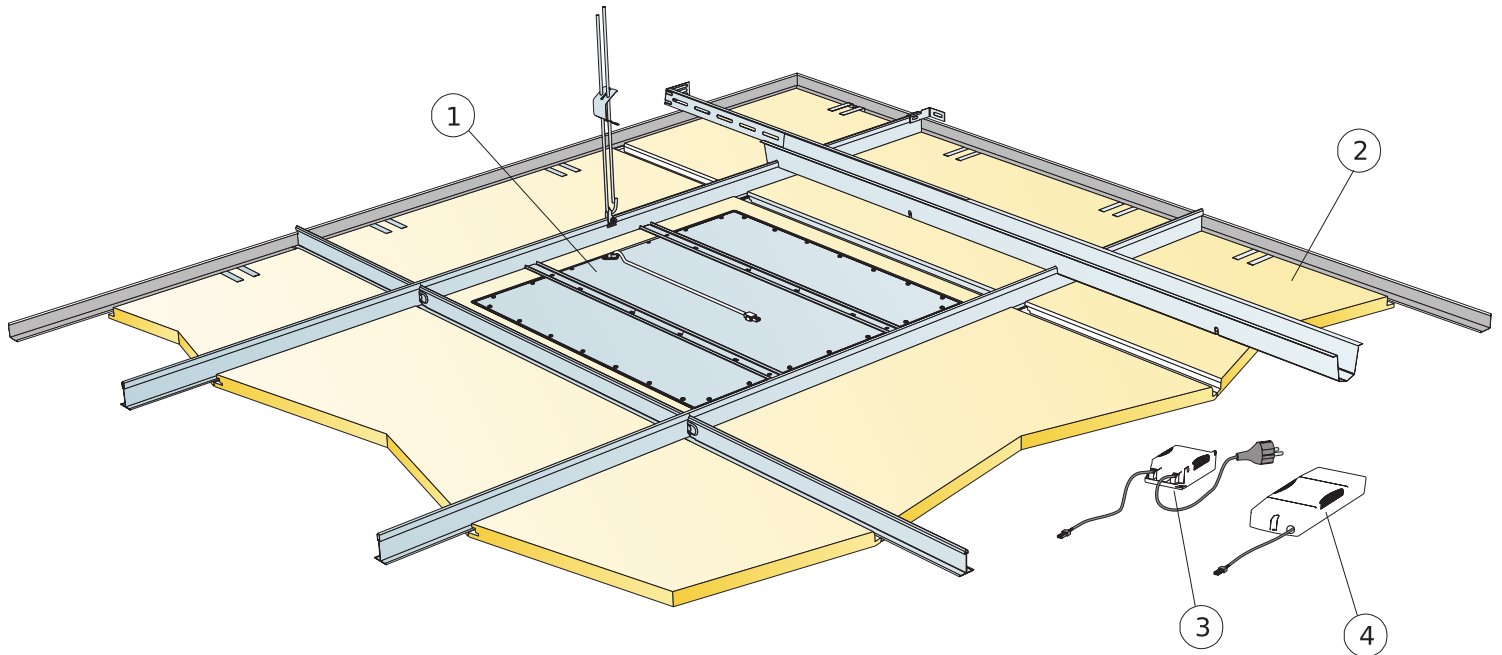

© Ecophon Group

QUANTITY SPECIFICATION (EXCL. WASTAGE)

	Size, mm
	600x600
1 Ecophon Dot/Square LED Ds Kit	1/luminaire
2 Focus Ds [adjacent ceiling]	as required
3 Ecophon Dot/Square/Line standard On/Off Ballast (included) [Alt.1]	-
4 Ecophon Dot/Square/Line SwitchDIM/DALI Ballast (included) [Alt.2]	-
Δ Min. overall depth of system: 115 mm	-
δ Min. demounting depth: 50 mm	-
When selecting standard on/off ballast, connect only to a toggle power switch. When using the SwitchDIM/DALI ballast connecting the SwitchDIM function, use a spring loaded power switch.	-
When selecting the SwitchDIM/DALI ballast utilizing the DALI function, connect only to a DALI compatible controller.	-

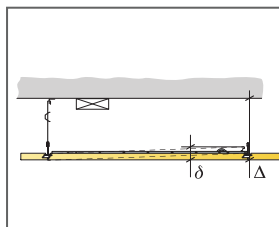

See Quantity Specification

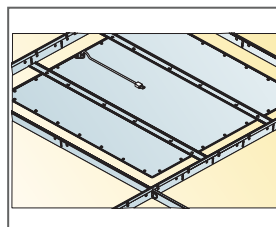

Dot Ds luminaire house resting on main runner

Size, mm	Max live load [N]	Min load bearing capacity [N]
600x600x20	0	160
600x600x40	0	160

Live load/load bearing capacity

INSTALLATION DIAGRAM (M518) FOR ECOPHON DOT LED DG, E, EG AND EZ

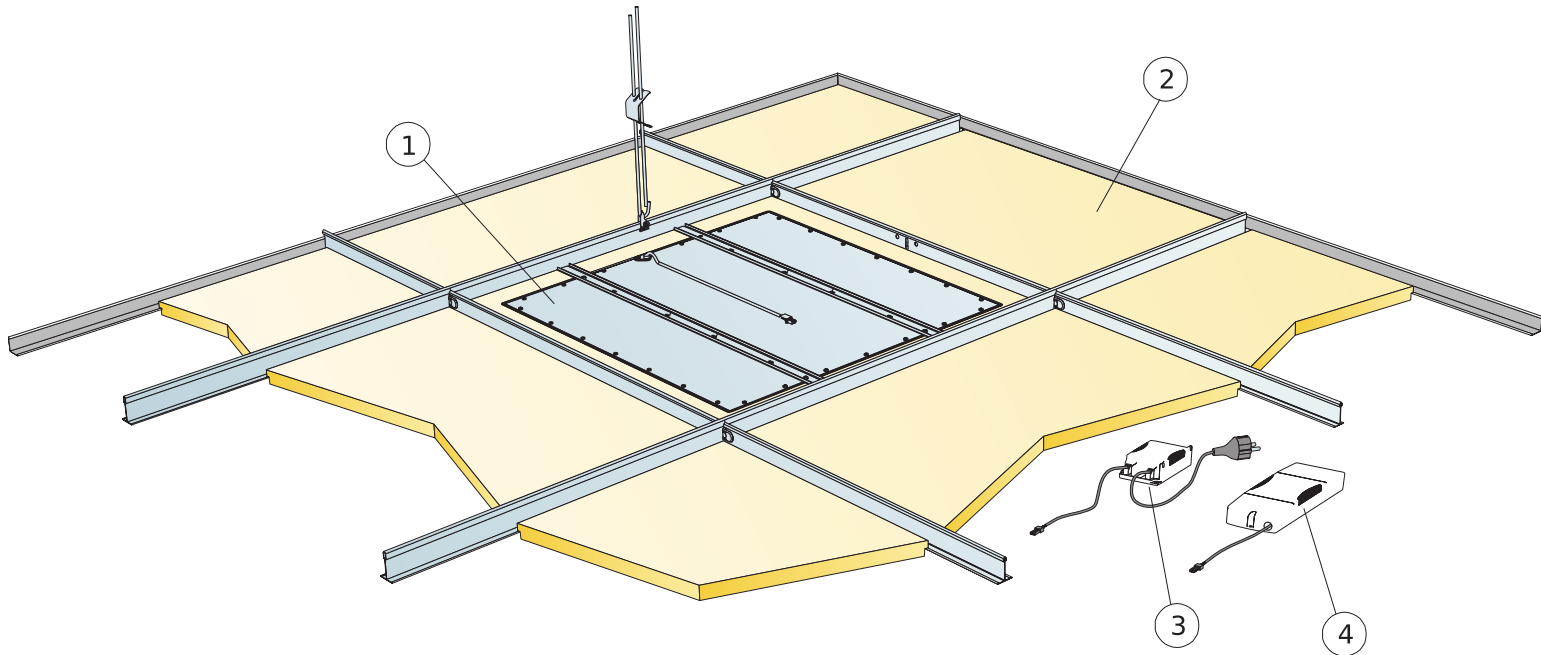

© Ecophon Group

QUANTITY SPECIFICATION (EXCL. WASTAGE)

	Size, mm
	600x600
1 Ecophon Dot/Square LED Dg, E, Eg or Ez Kit	1/luminaire
2 Focus Dg, E, Eg or Ez T24 (adjacent ceiling)	as required
3 Ecophon Dot/Square/Line standard On/Off Ballast (included) (Alt.1)	-
4 Ecophon Dot/Square/Line SwitchDIM/DALI Ballast (included) (Alt.2)	-
Δ Min. overall depth of system: 115 mm	-
δ Min. demounting depth: 50 mm	-
When selecting standard on/off ballast, connect only to a toggle power switch. When using the SwitchDIM/DALI ballast connecting the SwitchDIM function, use a spring loaded power switch.	-
When selecting the SwitchDIM/DALI ballast utilizing the DALI function, connect only to a DALI compatible controller.	-

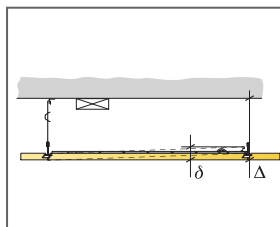

See Quantity Specification

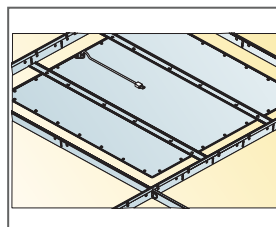

Dot Dg, E, Eg and Ez luminaire house resting on main runner

Size, mm	Max live load (N)	Min load bearing capacity (N)
600x600x20	0	160
600x600x40	0	160

Live load/load bearing capacity